

# Edge Gateway (EE-01)



## SPECIFICATION

The Enlighted Edge Gateway appliance hosted on the Siemens Connect X300 appliance device is installed in buildings utilizing the Enlighted system. The Edge Gateway offers an enhanced BACnet stack with an improved data-point hierarchy and naming convention nomenclature. The MQTT communication protocol allows sharing data collected by the Enlighted system with third-party data collection servers. The Edge Gateway facilitates low-latency inputs from on-premises third-party systems and enhances on-premises Manage or Manage in the Cloud (EMC) installations.

### OVERVIEW

The Enlighted Edge Gateway consists of the Enlighted Edge software hosted on the Siemens Connect X300 appliance. This solution is a bridge device that allows for on-site low-latency lighting control independent of Manage. The Enlighted Edge is also a translation device to third-party systems that provides bidirectional data flows to optimize building performance.

The Enlighted Edge software is installed and updated on the X300 device via the Siemens Cloud for security reasons. The X300 device activation and software installation is completed prior to shipment. Software updates are available through connection with the Siemens Cloud.

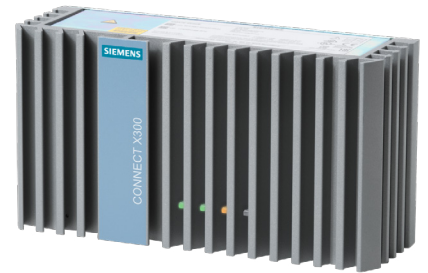

Enlighted Edge Gateway/X300 Appliance

|        |         |        |
|--------|---------|--------|
| Width  | 7.52"   | 191 mm |
| Height | 3.94"   | 100 mm |
| Depth  | 2.36"   | 60 mm  |
| Weight | 3.5 lbs | 1590 g |

### FEATURES

#### System Functionality Enhancements

- Provides MQTT telemetry data streams from Enlighted System to customer's data repositories
- Enables Manage migration to Cloud (EMC) while maintaining support for on-premise Building Management System (BMS) integration via BACnet/IP
- Enlighted Edge Gateway allows for an on-premise Manage installation to be migrated to an Enlighted Manage in the Cloud (EMC) deployment
- Provides low-latency lighting control from third-party systems such as KNX switches
- Integrates with Siemens Desigo Room Automation via BACnet/IP
- Enhances the Manage Lighting portfolio performance
- Enables Cross Gateway communication of Switch and Motion Groups
- All of the above offered modules can be enabled or disabled as per license agreement

#### Third-party Integrations

- Enhanced BACnet stack optimizes BMS integration
- Supports interfaces, such as
  - Dry Contact Closure
  - BACnet/IP systems
  - DTDL Protocol
  - UDMI Protocol
  - IBM Cloud
  - Desigo TRA system

#### Requirements

- 24 VDC Power Supply
- DIN Rail Mounting
- Ethernet connection for Manage and Enlighted Gateways
- Internet connection for setup and updates



HDR-60-24 Edge Gateway Power Supply

### ENLIGHTED SPECIFICATION SUBMITTAL

Job Name:

Job Number:

Product Codes:

EE-01

HDR-60-24

# Edge Gateway (EE-01)

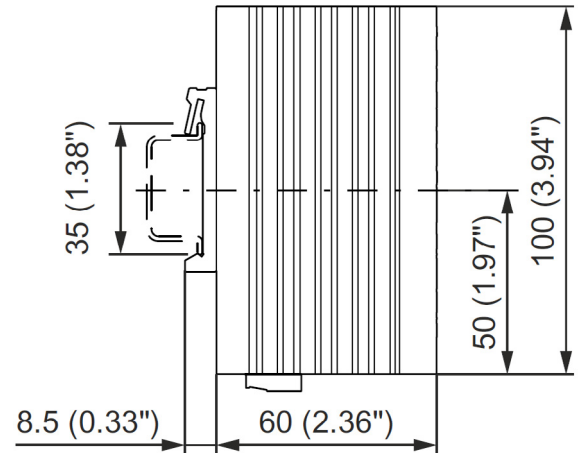
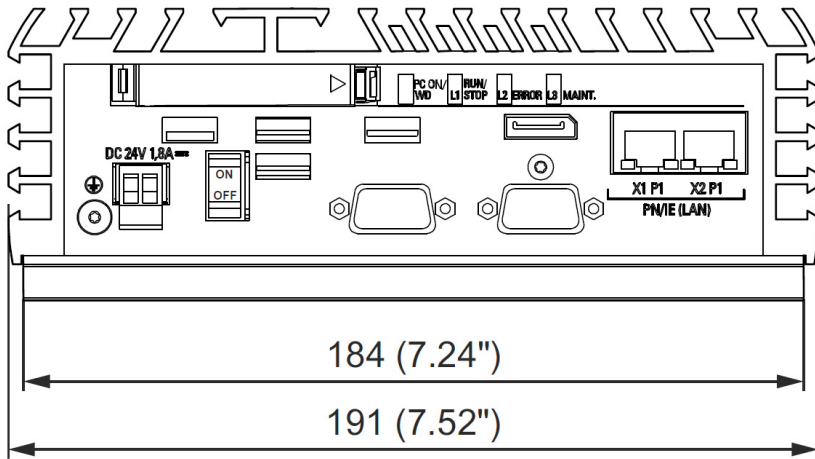

Dimensions in mm and inches

## WALL MOUNTING (DIN RAIL NOT INCLUDED)

Make sure the substructure can bear four times the total weight of the device.

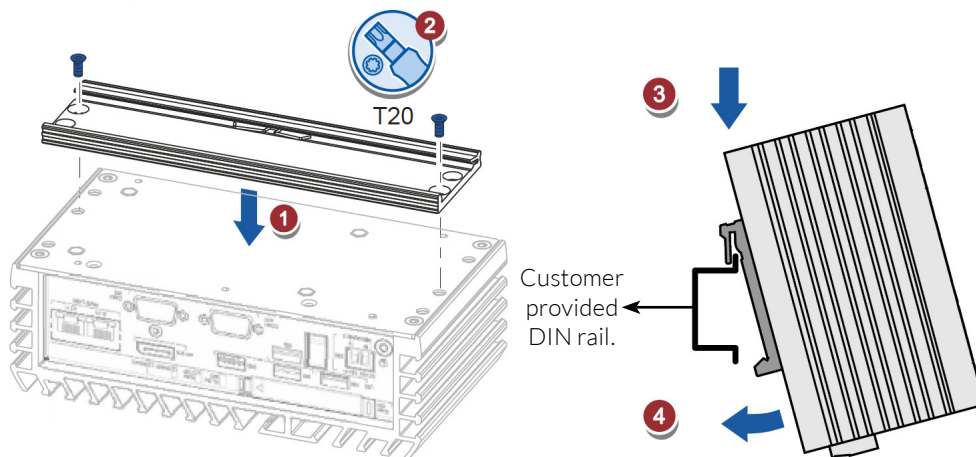

Tighten the screws firmly (max. torque 5Nm/3.7 lbf ft).

## TECHNICAL SPECIFICATIONS

**Operating System:** Embedded Linux  
**Operating Voltage:** DC 24V  
**Air Humidity:** 5...85% at 30° C (86° F)  
**Operating:** 32° to 122° F / 0° to 50° C  
**Power Consumption:** Max. 1.8A/43W  
 at DC 24V = Typically 510 mA/13 W  
**Enclosure:** Ruggedized aluminum  
**Weight:** 3.5 lbs/1590g

## ORDERING INFORMATION

EE-01 Edge Gateway Appliance.  
 Includes perpetual license to the Enlighted Gateway Edge Software and one-year software upgrade subscription  
 HDR-60-24 Edge Gateway Power Supply (component to be ordered or provided by the customer)

## COMPLIANCE

Europe RoHS   
 United States   
 Canada

This device complies with part 15 of the FCC Rules. Operation is subject to the following two conditions: (1) This device may not cause harmful interference, and (2) this device must accept any interference received, including interference that may cause undesired operation.

## WARRANTY: 5 years

View [www.enlightedinc.com/limited-warranty-terms](http://www.enlightedinc.com/limited-warranty-terms) for complete terms and conditions.